



Performance & Productivity

- Very good working envelope
- Vertical arm rise up
- Outstanding RT capabilities
- basket load capacity 550 lbs
- Dual load 550-770 lbs (option)

Safety & Comfort

- Fully proportional and simultaneous movements
- Activ' Lighting System safe load (option)
- Haulotte Activ' Shield Bar 2.0 (option)

Maximized Total Cost of Ownership

- Haulotte Activ' Screen on board diagnostic tool
- Haulotte Stop Emission System which automatically turns the engine off & on
- Easy access to all components
- Modular basket quick and easy to repair

Haulotte



HA80 RTJ O



ROUGH TERRAIN ARTICULATED BOOMS



TECHNICAL DATA

HA80 RTJ O

Working height	86 ft 1 in
Platform height	80 ft 1 in
Horizontal outreach	57 ft 5 in
Up and over height	30 ft 6 in
Lift capacity	550 lbs
F x G Platform size	8 ft x 3 ft
A Length	38 ft 8 in
B Width	8 ft 2 in
C Height - stowed	9 ft 9 in
H Transport length	30 ft 10 in
J Transport height	9 ft 9 in
Vertical jib rotation	133° (-65°/+68°)
Platform rotation	180°
Turntable rotation	360° continuous
Tailswing	30 in
D Wheelbase	9 ft 2 in
Ground clearance	19 in
Tilt alarm	4°
Drive speed	3.1 mph
Gradeability	45 %
Tires - solid rough terrain	cured on 385/65-22.5
Turning radius - outside	21 ft 6 in
Engine	Kubota 48.6kW (66hp), T4f
Weight	34,100 lbs

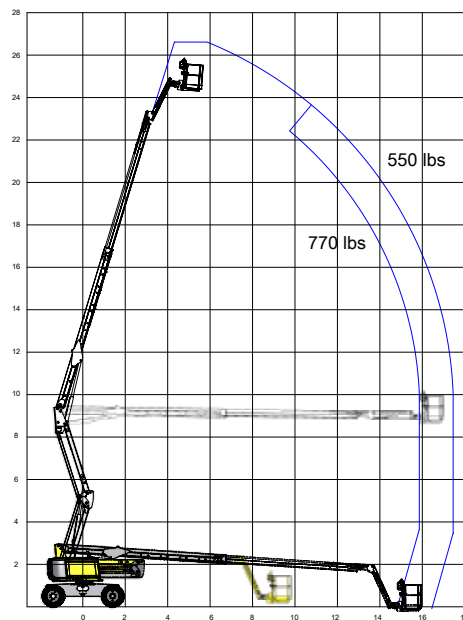
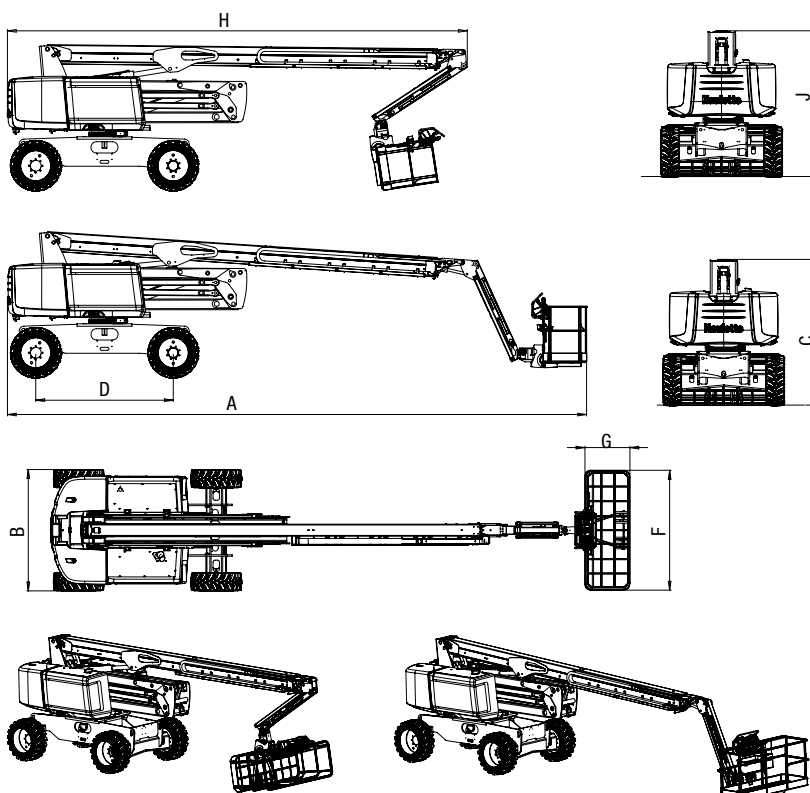

STANDARD EQUIPMENT

- 4 wheel drive, 2 wheel steer
- Front oscillating axle
- Automatic differential wheel lock
- 550 lbs (2 persons) load capacity unrestricted working envelope
- 4 simultaneous movements
- Embedded diagnostic system Haulotte Activ' Screen on lower control box, with color screen
- Haulotte Stop Emission System : automatic engine stop system
- Modular standard basket 8 ft x 3 ft
- Drop bar entry gate
- Upper control box cover
- Tool tray
- Swing out engine tray
- Low fuel level indicator (upper & lower control box)
- AC power to platform (110 / 230V)
- Engine pre-heater with light indicator
- 12V battery
- Electric pump system and emergency descent
- Sound and light alarm for tilt and load
- Travel alarm
- Rotating beacon
- Universal telematics plug

OPTIONS AND ACCESSORIES

- Activ' Lighting System, Safe load
- Activ' Shield Bar 2.0
- Dual load capacity 550 / 770 lbs
- Hydraulic generator 3.5 kW or 6.5 kW
- Power to platform (female plug in the basket)
- Air-line to platform
- Glazier pack
- Pipe cradle
- Working light
- Biodegradable hydraulic oil
- Cold weather kit -4° / Arctic weather kit -13°
- Hydraulic oil cooler
- Non-marking tires
- Battery circuit breaker